



**Washer**  
Extractor

**HC Series (Coin Equipment)**

MODEL : HC-20, HC-30, HC-40, HC-60

# SPECIFICATION

## Standard Features :

- Advanced Microcomputer. 10 Preset Factory Program. 30 Programmable Cycles (WE03 Coin Controller).
- 90 G Extraction Force.
- 3 Compartment Supply Dispensers on Top.
- Built-in Vacuum Breaker
- 4 Connections & Flush for Central Liquid Chemical Supply.
- All part in contact with wash solution made of 304 (18/8) Stainless steel.
- Metallic Anthracite Grey Cabinet Front, Sides and Top Panels.
- External Hot Water Supplied, Prepared For Direct Steam Connection.
- Single Rear Drain Connection.
- Single Motor Inverter Driven – Programmable Variable Speed.
- Robust Gamma A-Frame.
- 3 Water Levels (L, M, H).
- Coin Controller System.
- Programmable Water Temperature

## Optional Features :

- Stainless Steel Full Front Cabinet Panel
- Full Stainless Steel Cabinet Front & Sides
- Direct Steam Heating
- Electrical Heating
- EMI Filter for CE
- Special Voltage Modifications

## Colors Available :



White Silver Blue Orange

MODEL			HC-20	HC-30	HC-40	HC-60
Units of Measurement	Metric	US				
Maximum Capacity	kg.	lbs.	9 (20)	13.6 (30)	18.1 (40)	27.2 (60)
<b>Overall Dimensions :</b>						
A - Machine Width	mm.	inch	663 (26.1")	735 (28.9")	785 (30.9")	880 (34.6")
B - Machine Depth	mm.	inch	830 (32.7")	949 (37.4")	1132 (44.6")	1182 (46.5")
C - Machine Height	mm.	inch	1201 (47.3")	1284 (50.6")	1313 (51.7")	1530 (60.2")
<b>Cylinder Information :</b>						
Basket Diameter	mm.	inch	(24")	610 (24")	680 (26.8")	790 (31.1")
Basket Depth	mm.	inch	345 (13.5")	470 (18.5")	525 (20.7")	595 (23.4")
Basket Volume	cu.m	cu.ft	0.11 (4)	0.14 (5)	0.19 (7)	0.29 (10)
<b>Door Opening and Height :</b>						
Door opening Diameter	mm.	inch	365 (14.4")	365 (14.4")	365 (14.4")	450 (17.7")
Height of Door Bottom Above Floor	mm.	inch	387 (15.2")	445 (17.5")	465 (18.3")	540 (21.3")
<b>Drive Information :</b>						
Number of Motors	Number		1	1	1	1
Size of Motor	kW	HP	0.75 (1)	1.5 (2)	2.2 (3)	3.7 (5)
<b>Cylinder Speeds :</b>						
Wash	RPM	G-Force	48.5 (0.8)	48.5 (0.8)	48 (0.8)	43 (0.8)
Distribution	RPM	G-Force	76.5 (2)	77 (2)	70.2 (2)	67 (2)
Extract	RPM	G-Force	570 (111)	527 (95)	498 (94)	583 (150)
<b>Water Inlets and Consumption :</b>						
Hot Water Size	NPT		3/4"	3/4"	3/4"	3/4"
Cold Water Size	NPT		3/4"	3/4"	3/4"	3/4"
Additional Water Inlet	NPT		3/4"	3/4"	3/4"	3/4"
Average HOT Water Consumption/Cycle	liters	gal	91 (24)	91 (24)	193 (51)	223 (59)
Average COLD Water Consumption/Cycle	liters	gal	174 (46)	174 (46)	102 (27)	106 (28)
<b>Drain Outlets and Capacity :</b>						
Number of Drains	Number		1	1	1	1
Drain Size	mm.	inch	50.8 (2")	50.8 (2")	50.8 (2")	76.2 (3")
Drain Capacity	liters/min	gpm	117 (31)	117 (31)	310 (81.9)	581 (153.5)
<b>Steam Inlet and Consumption :</b>						
Steam Inlet Connection	NPT		1/2"	1/2"	1/2"	1/2"
Steam Pressure	bar	Psi	6 (100)	6 (100)	6 (100)	6 (100)
Steam Consumption	kg/hr	lb/hr	11 (24.15)	11 (24.15)	23.5 (51.75)	34.4 (75.9)
<b>Weight and Shipping Information :</b>						
Net Weight (approx.)	kg.	lbs.	240 (530)	286 (630.5)	437 (963.4)	499 (1100)
Domestic Shipping weight (approx.)	kg.	lbs.	286 (630.5)	302 (665.8)	455 (1003)	519 (1144)

Specification of design is subject to change without notice. For additional options please consult factory and distributor.

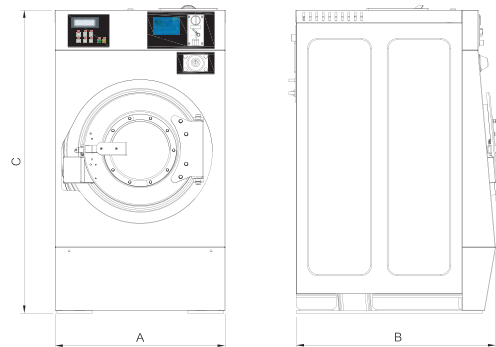

ISO 9001 : 2008

ISO 14001 : 2004